

R. C. Tronics, Incorporated

Specializing In Electronic Controls

AUGUST 23, 2022

2573 East Kercher Road

Goshen, Indiana 46528

<https://www.rctronics.com>

Phone: 1-574-642-3857

Fax: 1-574-642-3858

Toll Free: 1-866-457-7790

RCT-01760-O TRANSIT BUS BOOKLET



R. C. ELECTRONICS INCORPORATED

2573 East Kercher Road
Goshen, Indiana 46526
<https://www.rcetronics.com>

Phone: 1-574-642-3857
Fax 1-574--642-3858
Toll Free: 1-866-457-7790

RCT-01760-O PLUG-IN-PLAY BUS POWER CENTER EXPANDED FEATURE MICRO-RELAY SYSTEM

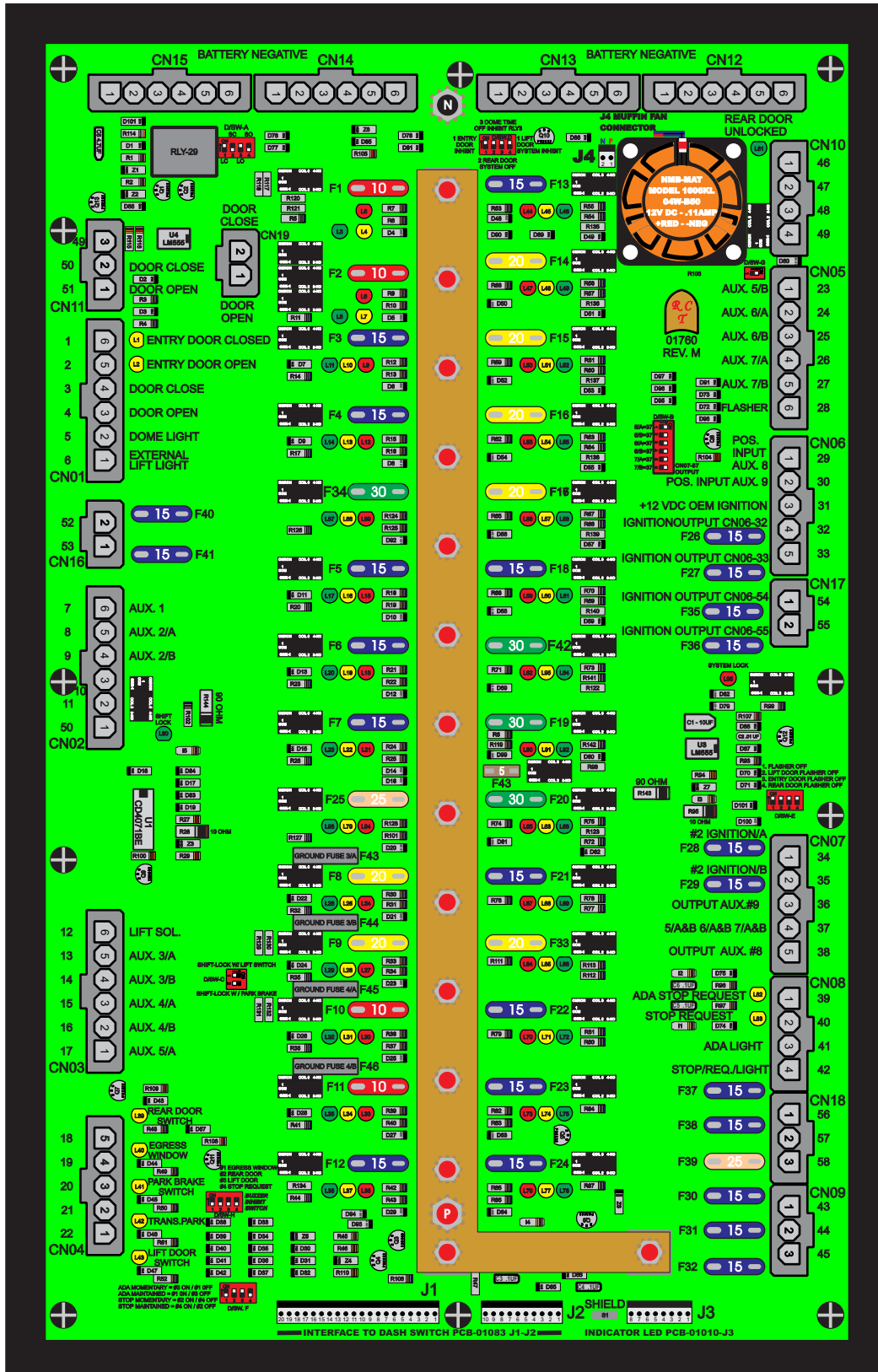

R.C. TRONICS, INCORPORATED

2573 EAST KERCHER ROAD
GOSHEN, INDIANA 46526
<https://www.rctronics.com>

PHONE: 1-574-642-3858
FAX: 1-574-642-3858
TOLL FREE: 1-866-457-7790

Power Center RCT-01760-O Molex Connectors

CN01

- 1 Door Closed Limit Input **NEG (sink)**
- 2 Door Open Limit Input **NEG (sink)**
- 3 Door Close Motor Output **NEG (sink)**
- 4 Door Open Motor Output **NEG (sink)**
- 5 Dome Light **12 VDC (+)**
- 6 External Lift Light **12 VDC (+)**

CN02

- 7 Aux. 1 Out **12 VDC (+)**
- 8 Aux. 2/A Out **12 VDC (+)**
- 9 Aux. 2/B Out **12VDC (+)**
- 10 Shift Lock NC (ISOLATED CONTACT)
- 11 Shift Lock NO (ISOLATED CONTACT)
- 50 Shift Lock COM (ISOLATED CONTACT)

CN03

- 12 Lift Solenoid Output **12 VDC (+)**
- 13 Aux. 3/A Out **12 VDC (+)**
- 14 Aux. 3/B Out **12 VDC (+)**
- 15 Aux. 4/A Out **12 VDC (+)**
- 16 Aux. 4/B Out **12 VDC (+)**
- 17 Aux. 5/A Out **12VDC (+)**

CN04

- 18 Rear Door Switch Input **NEGATIVE (sink)**
- 19 Egress Window Input **NEGATIVE (sink)**
- 20 Park Brake Switch Input **NEGATIVE (sink)**
- 21 Transmission in "Park" Input **NEGATIVE (sink)**
- 22 Lift Door Switch Input **NEGATIVE (sink)**

CN05

- 23 Aux. 5/B Out **12 VDC (+)**
- 24 Aux. 6/A Out **12 VDC (+)**
- 25 Aux. 6/B Out **12 VDC (+)**
- 26 Aux. 7/A Out **12 VDC (+)**
- 27 Aux. 7/B Out **12 VDC (+)**
- 28 "Flasher" Output **12 VDC (+)**

CN06

29 Input Aux. 8 12 VDC (+)
30 Input Aux. 9 12 VDC (+)
31 Input Ignition 12 VDC (+)
32 Ignition Output 12 VDC (+)
33 Ignition Output 12 VDC (+)

CN07

34 Ignition Output 12 VDC (+)
35 Ignition Output 12 VDC (+)
36 Aux. 9 Output 12 VDC (+)
37 DSW-B Output 12 VDC (+)
38 Aux. 8 Output 12 VDC (+)

CN08

39 ADA Stop Input **NEGATIVE (sink)**
40 Stop/Req Input **NEGATIVE (sink)**
41 ADA Light Output 12 VDC (+)
42 Stop/Req Light Output 12v (+)

CN09

43 Battery Output 12 VDC (+)
44 Battery Output 12 VDC (+)
45 Battery Output 12 VDC (+)

CN10

46 Rear Door input **NEGATIVE (sink)**
47 Lock Relay Common (ISOLATED CONTACT)
48 Lock Relay N.O. (ISOLATED CONTACT)
49 Lock Relay N.C. (ISOLATED CONTACT)

CN11

49 **NEG (-)**
50 Entry Door Close Motor Output 12 VDC (+)
51 Entry Door Open Motor Output 12 VDC (+)

CN12, CN13, CN14, CN15

(6) **NEGATIVE** Each
Total of 24 Connections

CN17

54 Ignition Output 12 VDC (+)
55 Ignition Output 12 VDC (+)

CN18

56 Battery Output 12 VDC (+)

57 Battery Output 12 VDC (+)

58 Battery Output 12 VDC (+)

CN19

Entry Door Close Motor Output 12 VDC (+)

Entry Door Open Motor Output 12 VDC (+)

R.C. TRONICS, INCORPORATED

2573 EAST KERCHER ROAD
GOSHEN, INDIANA 46526
<https://www.rctronics.com>

PHONE: 1-574-642-3858
FAX: 1-574-642-3858
TOLL FREE: 1-866-457-7790

RCT-01760-O – DATA CONNECTORS - J1-J2-J3

POWER CENTER RCT-01760-O / J1-J2 TO DASH SWITCH PCB-01083 / J1-J2

- J1-01* -- Ignition (+12 VDC) (To J3-8 and J3-7) (*J2-1* Aux. 5/B Switch) (sink) (To J4-5)
 - J1-02* -- Buzzer Output (sink) (*J2-2* Aux. 6/A Switch) (sink) (To J4-4)
 - J1-03* -- Entry Door Light (sink) (To J3-6) (*J2-3* Aux 6/B Switch) (sink) (To J4-3)
 - J1-04* -- Stop Request (sink) (To J3-5) (*J2-4* Aux 7/A Switch) (sink) (To J4-2)
 - J1-05* -- Rear Door Light (sink) (To J3-4) (*J2-5* Aux. 7/B Switch) (sink) (To J4-1)
 - J1-06* -- Egress Windows (sink) (To J3-3) (*J2-6* Master Switch) (sink)
 - J1-07* -- ADA Stop Request (sink) (To J3-2) (*J2-7* Flasher Switch) (sink)
 - J1-08* -- Lift Door Light (sink) (To J3-1) (*J2-8* Battery Negative (-))
 - J1-09* -- Aux. 5/A Switch (sink) (To J4-6) (*J2-9* Clearance Light Power) (+12 VDC)
 - J1-10* -- Aux 4/B Switch (sink) (To J4-7) (*J2-10* OPEN)
 - J1-11* -- Aux. 4/A Switch (sink) (To J4-8)
 - J1-12* -- Aux 3/B Switch (sink) (To J4-9)
 - J1-13* -- Aux. 3/A Switch (sink)
 - J1-14* -- Aux. 2/A Switch (sink)
 - J1-15* -- Aux. 2/B Switch (sink)
 - J1-16* -- Aux. 1 Switch (sink)
 - J1-17* -- Lift Solenoid Switch (sink)
 - J1-18* -- Dome Light Switch (sink)
 - J1-19* -- Entry Door Close Switch (sink)
 - J1-20* -- Entry Door Open Switch (sink)
-
- J2-01* -- Aux. 5/B Switch (sink)(J4-5)
 - J2-02* -- Aux. 6/A Switch (sink) (To J4-4)
 - J2-03* -- Aux 6/B Switch (sink) (To J4-3)
 - J2-04* -- Aux 7/A Switch (sink) (To J4-2)
 - J2-05* -- Aux. 7/B Switch (sink) (To J4-1)
 - J2-06* -- Master Switch (sink)
 - J2-07* -- Flasher Switch (sink)
 - J2-08* -- Battery Negative (-)
 - J2-09* -- Clearance Light Power (+12 VDC)
 - J2-10* -- +12 VDC (not fused - 0-ohm resistor R47 on RCT-01760-M)

J3 Connector, Indicating Lights

- J3-1*** - Shift Lock (**sink**) @ 1 ampere maximum)
- J3-2*** - Transmission Park (**sink**) @ 1 ampere maximum)
- J3-3*** - Lift Enable (**sink**) @ 1 ampere maximum)
- J3-4*** - Park Break Set (**sink**) @ 1 ampere maximum)
- J3-5*** - Lift Door Open (**sink**) @ 1 ampere maximum)
- J3-6*** - Lift Switch On (**sink**) @ 1 ampere maximum)
- J3-7*** - Ignition (+12 VDC), switched)
- J3-8*** - Ignition (+12 VDC), switched)

R.C. TRONICS, INCORPORATED

2573 EAST KERCHER ROAD
GOSHEN, INDIANA 46526
<https://www.rctronics.com>

PHONE: 1-574-642-3858
FAX: 1-574-642-3858
TOLL FREE: 1-866-457-7790

DASH SWITCH PCB-01083

DASH SWITCH PCB-01083/J1-J2 TO POWER CENTER RCT-01760-O/J1-J2

- J1-01** -- Ignition (+12 VDC) (To J3-8 and J3-7) (**J2-1** Aux. 5/B Switch) (**sink**) (To J4-5)
 - J1-02** -- Buzzer Output (**sink**) (**J2-2** Aux. 6/A Switch) (**sink**) (To J4-4)
 - J1-03** -- Entry Door Light (**sink**) (To J3-6) (**J2-3** Aux 6/B Switch) (**sink**) (To J4-3)
 - J1-04** -- Stop Request (**sink**) (To J3-5) (**J2-4** Aux 7/A Switch) (**sink**) (To J4-2)
 - J1-05** -- Rear Door Light (**sink**) (To J3-4) (**J2-5** Aux. 7/B Switch) (**sink**) (To J4-1)
 - J1-06** -- Egress Windows (**sink**) (To J3-3) (**J2-6** Master Switch) (**sink**)
 - J1-07** -- ADA Stop Request (**sink**) (To J3-2) (**J2-7** Flasher Switch) (**sink**)
 - J1-08** -- Lift Door Light (**sink**) (To J3-1) (**J2-8** Battery Negative (-))
 - J1-09** -- Aux. 5/A Switch (**sink**) (To J4-6) (**J2-9** Clearance Light Power) (+12 VDC)
 - J1-10** -- Aux 4/B Switch (**sink**) (To J4-7) (**J2-10** OPEN)
 - J1-11** -- Aux. 4/A Switch (**sink**) (To J4-8)
 - J1-12** -- Aux 3/B Switch (**sink**) (To J4-9)
 - J1-13** -- Aux. 3/A Switch (**sink**)
 - J1-14** -- Aux. 2/A Switch (**sink**)
 - J1-15** -- Aux. 2/B Switch (**sink**)
 - J1-16** -- Aux. 1 Switch (**sink**)
 - J1-17** -- Lift Solenoid Switch (**sink**)
 - J1-18** -- Dome Light Switch (**sink**)
 - J1-19** -- Entry Door Close Switch (**sink**)
 - J1-20** -- Entry Door Open Switch (**sink**)
-
- J2-01** -- Aux. 5/B Switch (**sink**) (To J4-5)
 - J2-02** -- Aux. 6/A Switch (**sink**) (To J4-4)
 - J2-03** -- Aux. 6/B Switch (**sink**) (To J4-3)
 - J2-04** -- Aux. 7/A Switch (**sink**) (To J4-2)
 - J2-05** -- Aux. 7/B Switch (**sink**) (To J4-1)
 - J2-06** -- Master Switch (**sink**)
 - J2-07** -- Flasher Switch (**sink**)
 - J2-08** -- Battery Negative (-)
 - J2-09** -- Clearance Light Power (+12 VDC)
 - J2-10** -- +12 VDC (not fused - 0-ohm resistor R47 on RCT-01760-M)

J3 Connector, Indicating Lights

- J3-1*** Lift Door Light, **(sink)** @ 1 ampere maxim) (From J1-8)
- J3-2*** ADA Stop Request, **(sink)** @ 1 ampere maxim) (From J1-7)
- J3-3*** Egress Windows, **(sink)** @ 1 ampere) (From J1-6)
- J3-4*** Rear Door Light, **(sink)** @ 1 ampere) (From J1-5)
- J3-5*** Stop Request, **(sink)** @ 1 ampere) (From J1-4)
- J3-6*** Entry Door Light, **(sink)** @ 1 ampere) (From J1-3)
- J3-7*** Ignition (+12 VDC), switched) (From J1-1)
- J3-8*** Ignition (+12 VDC), switched) (From J1-1)

J4 Connector, Spare Relays on Power Center PCB.

- J4-1*** Aux 7/B Switch **(sink)** (From J2-5)
- J4-2*** Aux 7/A Switch **(sink)** (From J2-4)
- J4-3*** Aux 6/B Switch **(sink)** (From J2-3)
- J4-4*** Aux 6/A Switch **(sink)** (From J2-2)
- J4-5*** Aux 5/B Switch **(sink)** (From J2-1)
- J4-6*** Aux 5/A Switch **(sink)** (From J1-9)
- J4-7*** Aux 4/B Switch **(sink)** (From J1-10)
- J4-8*** Aux 4/A Switch **(sink)** (From J1-11)
- J4-9*** Aux 3/B Switch **(sink)** (From J1-12)
- J4-10*** Battery Negative (-)

R.C. TRONICS, INCORPORATED

2573 EAST KERCHER ROAD
GOSHEN, INDIANA 46526
<https://www.rctronics.com>

PHONE: 1-574-642-3858
FAX: 1-574-642-3858
TOLL FREE: 1-866-457-7790

INDICATOR LIGHTS PCB-01010-J3 TO POWER CENTER RCT-01760-O / J3

1. Shift Lock. **(sink)** @ 1 ampere maximum
2. Transmission Park. **(sink)** @ 1 ampere maximum
3. Lift Enable. **(sink)** @ 1 ampere maximum
4. Park Brake Set. **(sink)** @ 1 ampere maximum
5. Lift Door Open. **(sink)** @ 1 ampere maximum
6. Lift Switch On. **(sink)** @ 1 ampere maximum
7. Ignition (**+12 VDC**, switched)
8. Ignition (**+12 VDC**, switched)

FACEPLATE NOMENCLATURE LEFT TO RIGHT ON PCB-01010

1. LIFT SWITCH
2. PARK BRAKE
3. IN PARK
4. SHIFT LOCK
5. LIFT DOOR
6. LIFT ENABLED

R.C. TRONICS, INCORPORATED

2573 EAST KERCHER ROAD
GOSHEN, INDIANA 46526
<https://www.rctronics.com>

PHONE: 1-574-642-3858
FAX: 1-574-642-3858
TOLL FREE: 1-866-457-7790

SWITCH CENTER RCT-01083 / J3 CONNECTION TO PCB-01010

1. Lift Door Light, **(sink)** @ 1 ampere maximum
2. ADA Stop Request, **(sink)** @ 1 ampere maximum
3. Egress Windows, **(sink)** @ 1 ampere maximum
4. Rear Door Light, **(sink)** @ 1 ampere maximum
5. Stop Request, **(sink)** @ 1 ampere maximum
6. Entry Door Light, **(sink)** @ 1 ampere maximum
7. Ignition (**+12 VDC**, switched)
8. Ignition (**+12 VDC**, switched)

PCB-01010 RENAMED

1. Shift Lock to; "ADA STOP"
2. In Park to; "LIFT DOOR"
3. Lift Enabled to; "ENTRY DOOR"
4. Park Brake to; "STOP REQUEST"
5. Lift Door to; "REAR DOOR"
6. Lift Switch to; "EGRESS WINDOW"

PCB-01083 FACEPLATE RENAME LEFT TO RIGHT

1. EGRESS WINDOW
2. STOP REQUEST
3. LIFT DOOR
4. ADA STOP
5. REAR DOOR
6. ENTRY DOOR

R.C. TRONICS, INCORPORATED

2573 EAST KERCHER ROAD
GOSHEN, INDIANA 46526
<https://www.rctronics.com>

PHONE: 1-574-642-3857
FAX: 1-574-642-3858
TOLL FREE: 1-866-457-7790

RCT-01760-O DIP SWITCH A, ELECTRIC DOOR OPEN AND CLOSE SETTING.

Friday, May 03, 2024

D/SWA-1 (ON): Travel Limit, Internal Ground Input @ CN01-1, "Entry Door is Closed". **- NO CONNECTION.**
D/SWA-2 (OFF): Removes the ability to Limit Travel @ CN01-1, "Entry Door is Closed". **- NO CONNECTION.**
D/SWA-3 (ON): Travel Limit, Internal Ground Input @ CN01-2 "Entry Door is Open". **- NO CONNECTION.**
D/SWA-4 (OFF): Removes the ability to Limit Travel @ CN01-2, "Entry Door is Open". **- NO CONNECTION.**

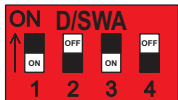

D/SWA-1 LC (INTERNAL LIMIT, "DOOR CLOSED")
D/SWA-2 SC (SELF LIMITING, "DOOR CLOSE") (USED WITH CURRENT LIMITING MOTOR CONTROL)
D/SWA-3 LO (INTERNAL LIMIT, "DOOR OPEN")
D/SWA-4 SO (SELF LIMITING, "DOOR OPEN") (USED WITH CURRENT LIMITING MOTOR CONTROL)

NOTE:

**PROTRUDING DIP-SWITCH TABS ARE ADJUSTMENT TABS SHOWN IN BLACK.
"ON & OFF" IS DEFINED IN BLACK ON WHITE BACKGROUND.**

NOTE:

DOME LIGHT OPERATES WITH D/SWD-3, "ON"

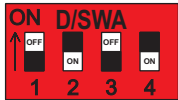

D/SWA-1 LC (EXTERNAL LIMIT, "DOOR CLOSED")
D/SWA-2 SC (SELF LIMITING, "DOOR CLOSE") (USED WITH CURRENT LIMITING MOTOR CONTROL)
D/SWA-3 LO (EXTERNAL LIMIT, "DOOR OPEN")
D/SWA-4 SO (SELF LIMITING, "DOOR OPEN") (USED WITH CURRENT LIMITING MOTOR CONTROL)

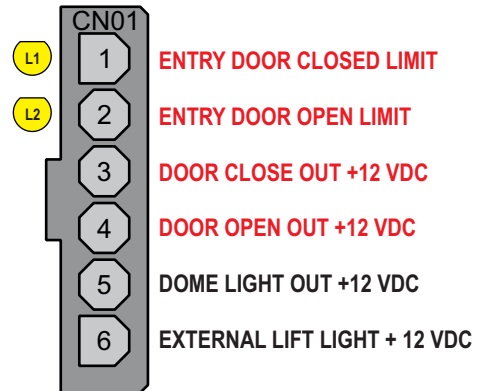

D/SWA-1 (OFF): Travel Limit, External Ground Input, @ CN01-1, "Entry Door is Closed". **SINK TO LIMIT.**
D/SWA-2 (ON): Provides the ability to Limit Travel @ CN01-1, "Entry Door is Closed". **SINK TO LIMIT.**
D/SWA-3 (OFF): Travel Limit, External Ground Input, @ CN01-2 "Entry Door is Open". **SINK TO LIMIT.**
D/SWA-4 (ON): Provides the ability to Limit Travel @ CN01-2, "Entry Door is Open". **SINK TO LIMIT.**

LOCATION: CN11 & CN01, TOP LEFT OF RCT-01760-O

1. NOTE: D/SW-A; Switches 2 & 4 "ON" and Switches 1 & 3 "OFF" to operate doors with **external limit switches connected to CN01-1 "Limit Door Close" and CN01-2 "Limit Door Open"**.
2. NOTE: D/SW-A; Switches 1 & 3 "ON" and Switches 2 & 4 "OFF", to operate doors with **internal limit switches connected to CN01-1 "Limit Door Close" and CN01-2 "Limit Door Open"**.
3. **Motor Outputs, CN01-3 "Door Close" and CN01-4 "Door Open", rated 12 vdc – 30 amperes.**

R.C. TRONICS, INCORPORATED

2573 EAST KERCHER ROAD
GOSHEN, INDIANA 46526
<http://www.rctronics.com>

PHONE: 1-574-642-3857
FAX: 1-574-642-3858
TOLL FREE: 1-866-457-7790

RCT-01760-O DIP-M SWITCH B, AUX 5-6-7 A & B ADD CN07-37 SETTING.

Tuesday, May 7, 2024

D/SWB-1 (OFF): CN03-17 12 VDC Output "Aux. 5/A / **no output at** / CN07 -37 +12 VDC DISABLED
D/SWB-2 (OFF): CN05-23 12 VDC Output "Aux. 5/B / **no output at** / CN07-37 +12 VDC DISABLED
D/SWB-3 (OFF): CN05-24 12 VDC Output "Aux. 6/A / **no output at** / CN07 -37 +12 VDC DISABLED
D/SWB-4 (OFF): CN05-25 12 VDC Output "Aux. 6/B / **no output at** / CN07 -37 +12 VDC DISABLED
D/SWB-5 (OFF): CN05-26 12 VDC Output "Aux. 7/A / **no output at** / CN07 -37 +12 VDC DISABLED
D/SWB-6 (OFF): CN05-27 12 VDC Output "Aux. 7/B / **no output at** / CN07 -37 +12 VDC DISABLED

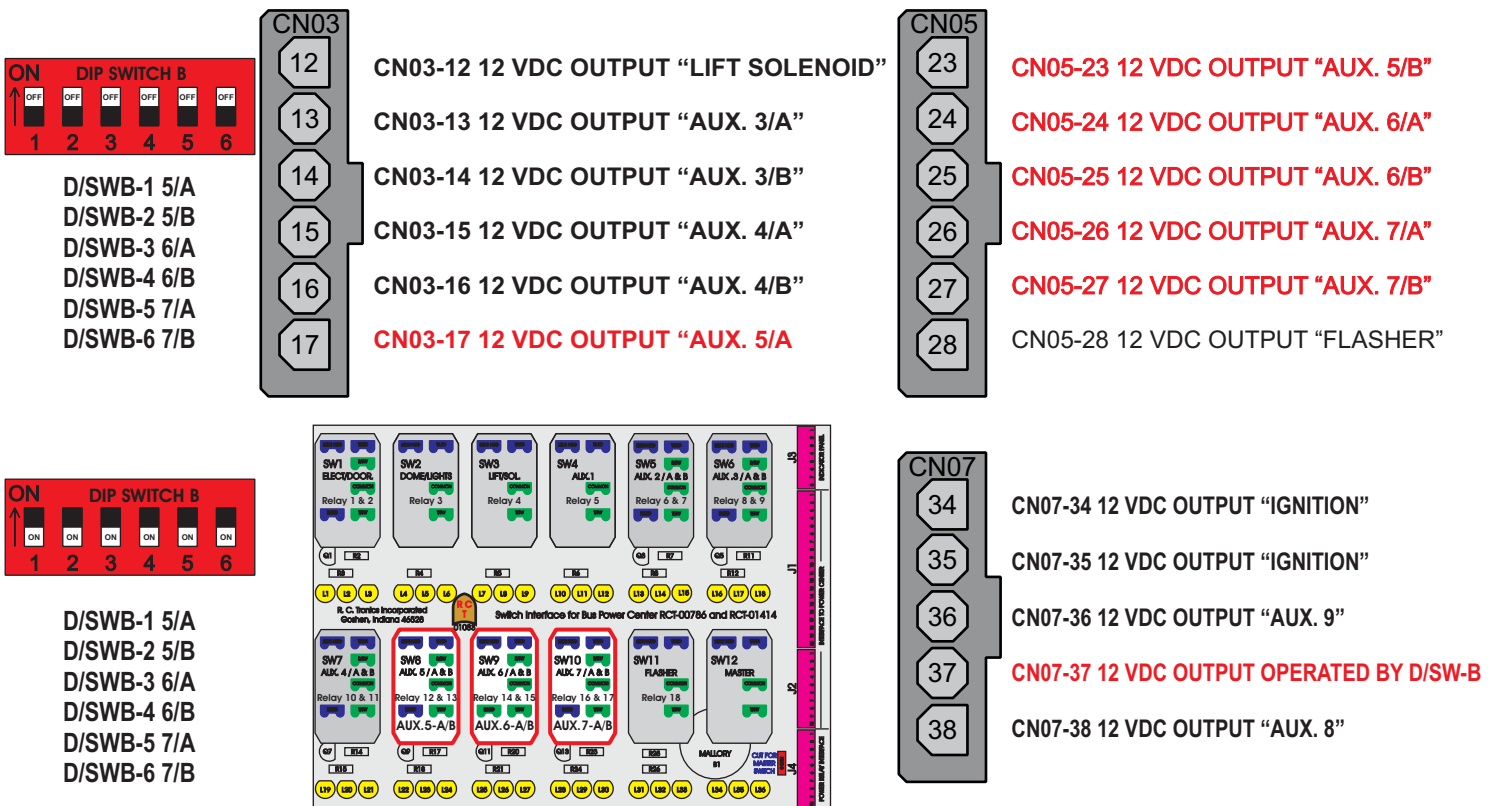

D/SWB-1 (ON): CN03-17 12 VDC Output "Aux. 5/A / **output at** / CN07 -37 +12 VDC ENABLED
D/SWB-2 (ON): CN05-23 12 VDC Output "Aux. 5/B / **output at** / CN07 -37 +12 VDC ENABLED
D/SWB-3 (ON): CN05-24 12 VDC Output "Aux. 6/A / **output at** / CN07 -37 +12 VDC ENABLED
D/SWB-4 (ON): CN05-25 12 VDC Output "Aux. 6/B / **output at** / CN07 -37 +12 VDC ENABLED
D/SWB-5 (ON): CN05-26 12 VDC Output "Aux. 7/A / **output at** / CN07 -37 +12 VDC ENABLED
D/SWB-6 (ON): CN05-27 12 VDC Output "Aux. 7/B / **output at** / CN07 -37 +12 VDC ENABLED

LOCATED: 1/3 DOWN RIGHT SIDE OF RCT-01760-O

- NOTE: This circuit was designed to accommodate up to three heating zones and output 12 volt output to a pump, (CN07-37) so as to provide heating, front, center and rear of the vehicle seating sections. In addition utilizing balance of dash mounted switches in event of single or double zoned heating arrangements.

NOTE:

**PROTRUDING DIP-SWITCH TABS ARE ADJUSTMENT TABS SHOWN IN BLACK.
"ON & OFF" IS DEFINED IN BLACK ON WHITE BACKGROUND.**

R.C. TRONICS, INCORPORATED

2573 EAST KERCHER ROAD
GOSHEN, INDIANA 46526
<https://www.rctronics.com>

PHONE: 1-574-642-3857
FAX: 1-574-642-3858
TOLL FREE: 1-866-457-7790

RCT-01760-O DIP SWITCH C, “SHIFT-LOCK” with, “LIFT SWITCH” or “PARK-BRAKE SWITCH”. Friday, May 3, 2024

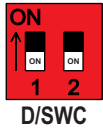

D/SWC-1 SHIFT-LOCK W / LIFT SWITCH
D/SWC-2 SHIFT-LOCK W / PARK BRAKE

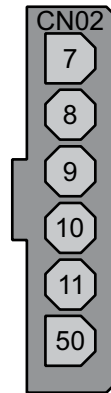

CN02-7 12 VDC OUTPUT “AUX. 1”

CN02-8 12 VDC OUTPUT “AUX. 2/A”

CN02-9 12 VDC OUTPUT “AUX. 2/B”

CN02-10 NORMALLY CLOSED CONTACT “SHIFT LOCK”

CN02-11 NORMALLY OPEN CONTACT “SHIFT LOCK”

CN02-50 COMMON “SHIFT LOCK”

1. NOTE: Circuit designed to lock vehicle, “Shift Lock” so that transmission cannot be removed from, “Park”.
- 2 D/SW-1, “Lift Switch” is set “ON” and/or D/SW-2, “Park Brake” is set “ON”.
- 3 Isolated contacts, CN02-50 (common), CN02-11 (normally open) and CN02-10 (normally closed) reverse contact state in reference to common.
- 2 Wiring to be accomplished by technician an by vehicle manufacture specifications

DIP SWITCH C LOCATED: 2/3 DOWN LEFT SIDE OF RCT-01760-O

NOTE:

**PROTRUDING DIP-SWITCH TABS ARE ADJUSTMENT TABS SHOWN IN BLACK.
“ON & OFF” IS DEFINED IN BLACK ON WHITE BACKGROUND.**

R.C. TRONICS, INCORPORATED

2573 EAST KERCHER ROAD
GOSHEN, INDIANA 46526
<https://www.rctronics.com>

PHONE: 1-574-642-3857
FAX: 1-574-642-3858
TOLL FREE: 1-866-457-7790

RCT-01760-O DIP SWITCH D, ENTRY DOOR-REAR DOOR-DOME LIGHT-LIFT DOOR SETTING.

Friday, May 5, 2024

- D/SWD-1 (ON): Inhibits operation of “Entry Door” open without “Transmission in Park”, CN04-21, Led “ON’.
D/SWD-1 (OFF): “Entry Door” operates without “Transmission in Park”, CN04-21, Led “OFF’.
D/SWD-2 (ON): “Rear Door” open @ CNO4-18, will lock Ignition System “ON”, with Red Led with Buzzer.
D/SWD-2 (OFF): “Rear Door” open, @ CN04-18 will not lock Ignition System, “ON”.
D/SWD-3 (ON): Inhibits operation of interior, “Dome Lights”, with operation of, “Entry Door”.
D/SWD-3 (OFF): Enables operation of interior, “Dome Lights”, with operation of, “Entry Door”.
D/SWD-4 (ON): “Lift Door” open @ CN04-22, will lock Ignition System “ON”, with Red Led with Buzzer.
D/SWD-4 (OFF): Lift Door” open, @ CN04-22 will not lock Ignition System “ON”.

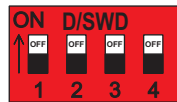

D/SWD-1 ENTRY DOOR INHIBIT
D/SWD-2 REAR DOOR SYSTEM OFF
D/SWD-3 DOME TIME OFF INHIBIT RLY3
D/SWD-4 LIFT DOOR SYSTEM INHIBIT

NOTE:

PROTRUDING DIP-SWITCH TABS ARE ADJUSTMENT TABS SHOWN IN BLACK.
“ON & OFF” IS DEFINED IN BLACK ON WHITE BACKGROUND.

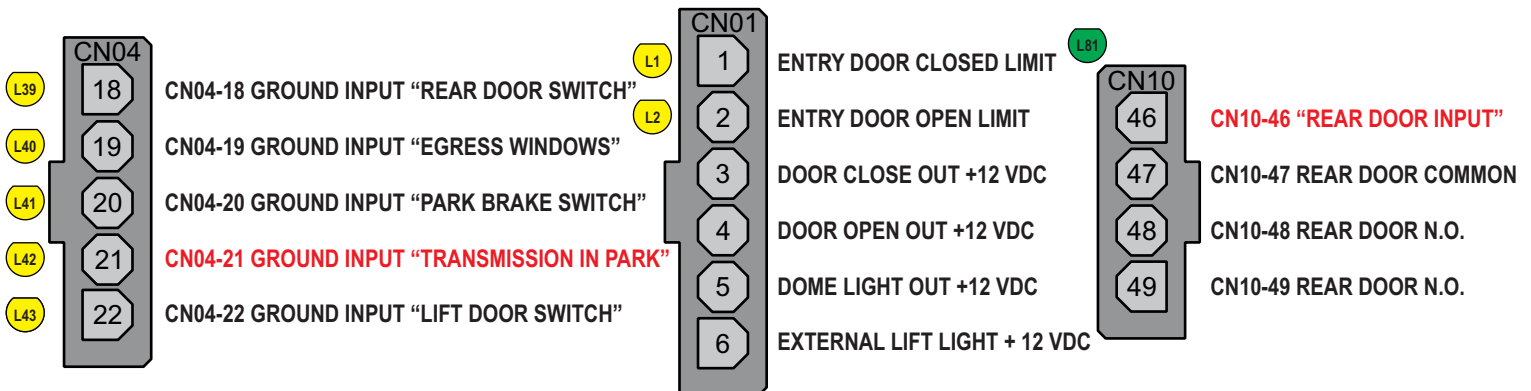

LOCATION: TOP LEFT CENTER OF RCT-01760-O

- NOTE: “System Lock” will not permit, shut a system shut down, either by removing “Master Switch” or “Ignition”. “Rear Door” and/or “Lift Door” must be checked and secured.
- NOTE: “Entry Door” with “Entry Door Inhibit”, D/SW-1 (ON) a sink input is at, “Transmission in Park”, CN04-21, Led “ON’ . This ensures that the vehicle cannot move during passenger loading.

R.C. TRONICS, INCORPORATED

2573 EAST KERCHER ROAD
GOSHEN, INDIANA 46526
<https://www.rctronics.com>

PHONE: 1-574-642-3857
FAX: 1-574-642-3858
TOLL FREE: 1-866-457-7790

RCT-01760-M DIP SWITCH E, LIFT DOOR-ENTRY DOOR-REAR DOOR ON OFF SETTING.

Saturday, April 1, 2023

D/SWE-1 (ON): “Flasher Switch ON”, constant output at CN05-28.

D/SWE-1 (OFF): “Flasher Switch ON”, alternating output at CN05-28.

D/SWE-2 (ON): “Flasher Switch OFF”, input CN04-22 “Lift Door Switch”, alternating output at CN05-28.

D/SWE-2 (OFF): “Flasher Switch OFF”, input CN04-22 “Lift Door Switch”, inhibits output at CN05-28.

D/SWE-3 (ON): “Flasher Switch OFF”, with CN11-04 “Entry Door Open”, alternating output at CN05-28.

D/SWE-3 (OFF): “Flasher Switch OFF” with CN11-04 “Entry Door Open”, inhibits output at CN05-28.

D/SWE-4 (ON): “Flasher Switch OFF” input CN04-18 “Rear Door Switch”, alternating output at CN05-28.

D/SWE-4 (OFF): “Flasher Switch OFF” input CN04-18 “Rear Door Switch”, inhibits output at CN05-28.

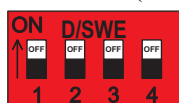

D/SWE-1 FLASHER OFF
D/SWE-2 LIFT DOOR FLASHER OFF
D/SWE-3 ENTRY DOOR FLASHER OFF
D/SWE-4 REAR DOOR FLASHER OFF



CN05-23 12 VDC OUTPUT “AUX. 5/B”

CN05-24 12 VDC OUTPUT “AUX. 6/A”

CN05-25 12 VDC OUTPUT “AUX. 6/B”

CN05-26 12 VDC OUTPUT “AUX. 7/A”

CN05-27 12 VDC OUTPUT “AUX. 7/B”

CN05-28 12 VDC OUTPUT “FLASHER”

LOCATION: RIGHT SIDE CENTER OF RCT-01760-M

1. NOTE: D/SWE-1 (OFF) provides constant output at CN05-28, with D/SWE-2 (ON) “Lift Door Switch”, D/SWE-3 (ON) “Entry Door Switch”, and/or D/SWE-4 (ON) “Rear Door Switch”.
2. NOTE: With D/SWITCH E 1 thru 4 “OFF”, output CN05-28 may be used as a normal output.

NOTE:

**PROTRUDING DIP-SWITCH TABS ARE ADJUSTMENT TABS SHOWN IN BLACK.
“ON & OFF” IS DEFINED IN BLACK ON WHITE BACKGROUND.**

R.C. TRONICS, INCORPORATED

2573 EAST KERCHER ROAD
GOSHEN, INDIANA 46526
<https://www.rctronics.com>

PHONE: 1-574-642-3857
FAX: 1-574-642-3858
TOLL FREE: 1-866-457-7790

RCT-01760-O DIP SWITCH F “ADA” AND STOP REQUEST MAINTAINED OR MOMENTARY. Saturday, May 4, 2024

ADA, “STOP REQUEST”, D/SWF SETTINGS

D/SW-F Switch 1 “ON” & Switch 3 “OFF” momentary input @ CN07-39, alternating buzzer – continuous.

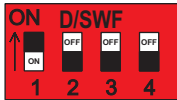

D/SWF-1 “ADA STOP REQUEST”, with “MOMENTARY INPUT” @ CN08-39 “ALTERNATING BUZZER CONTINUOUS”, *cancels with lift door opening @ CN04-22.*
D/SWF-2 “STOP REQUEST”, with “MOMENTARY INPUT” @ CN08-40, “MAINTAINED BUZZER” WITH INPUT ONLY”, *cancels with input removal @ CN08-40.*
D/SWF-3 “ADA STOP REQUEST”, with “MOMENTARY INPUT” @ CN08-39, “ALTERNATING BUZZER” WITH INPUT ONLY”, *cancels with input removal @ CN08-39.*
D/SWF-4 “STOP REQUEST”, with “MOMENTARY INPUT @ CN08-40”, MAINTAIN BUZZER CONTINUOUS”, *cancels with passenger door opening.*

D/SW-F Switch 1 “OFF” & Switch 3 “ON” momentary input @ CN07-39, alternating buzzer with input only.

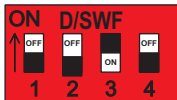

D/SWF-1 “ADA STOP REQUEST”, with “MOMENTARY INPUT” @ CN08-39 “ALTERNATING BUZZER CONTINUOUS”, *cancels with lift door opening @ CN04-22.*
D/SWF-2 “STOP REQUEST”, with “MOMENTARY INPUT” @ CN08-40, “MAINTAINED BUZZER” WITH INPUT ONLY”, *cancels with input removal @ CN08-40.*
D/SWF-3 “ADA STOP REQUEST”, with “MOMENTARY INPUT” @ CN08-39, “ALTERNATING BUZZER” WITH INPUT ONLY”, *cancels with input removal @ CN08-39.*
D/SWF-4 “STOP REQUEST”, with “MOMENTARY INPUT @ CN08-40”, MAINTAIN BUZZER CONTINUOUS”, *cancels with passenger door opening.*

D/SW-F Switch 1 & 3 “OFF”, “NO AUDIBLE ALARM” for “ADA STOP REQUEST”.

PASSANGER, “STOP REQUEST”, D/SWF SETTINGS

D/SW-F Switch 2 “OFF” & Switch 4 “ON”, momentary input @ CN07-40, continuous buzzer – continuous

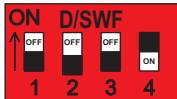

D/SWF-1 “ADA STOP REQUEST”, with “MOMENTARY INPUT” @ CN08-39 “ALTERNATING BUZZER CONTINUOUS”, *cancels with lift door opening @ CN04-22.*
D/SWF-2 “STOP REQUEST”, with “MOMENTARY INPUT” @ CN08-40, “MAINTAINED BUZZER” WITH INPUT ONLY”, *cancels with input removal @ CN08-40.*
D/SWF-3 “ADA STOP REQUEST”, with “MOMENTARY INPUT” @ CN08-39, “ALTERNATING BUZZER” WITH INPUT ONLY”, *cancels with input removal @ CN08-39.*
D/SWF-4 “STOP REQUEST”, with “MOMENTARY INPUT @ CN08-40”, MAINTAIN BUZZER CONTINUOUS”, *cancels with passenger door opening.*

D/SW-F Switch 2 “ON” & Switch 4 “OFF”, momentary input @ CN07-39, continuous buzzer with input only.

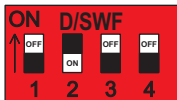

D/SWF-1 “ADA STOP REQUEST”, with “MOMENTARY INPUT” @ CN08-39 “ALTERNATING BUZZER CONTINUOUS”, *cancels with lift door opening @ CN04-22.*
D/SWF-2 “STOP REQUEST”, with “MOMENTARY INPUT” @ CN08-40, “MAINTAINED BUZZER” WITH INPUT ONLY”, *cancels with input removal @ CN08-40.*
D/SWF-3 “ADA STOP REQUEST”, with “MOMENTARY INPUT” @ CN08-39, “ALTERNATING BUZZER” WITH INPUT ONLY”, *cancels with input removal @ CN08-39.*
D/SWF-4 “STOP REQUEST”, with “MOMENTARY INPUT @ CN08-40”, MAINTAIN BUZZER CONTINUOUS”, *cancels with passenger door opening.*

D/SW-F Switch 2 & 4 “OFF”, “NO AUDIBLE ALARM” for “STOP REQUEST”.

NOTE:

**PROTRUDING DIP-SWITCH TABS ARE ADJUSTMENT TABS SHOWN IN BLACK.
“ON & OFF” IS DEFINED IN BLACK ON WHITE BACKGROUND.**

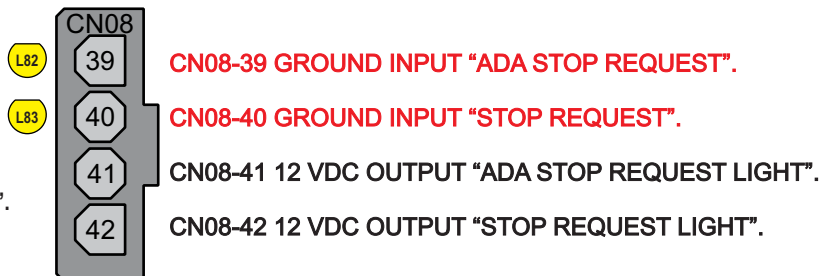
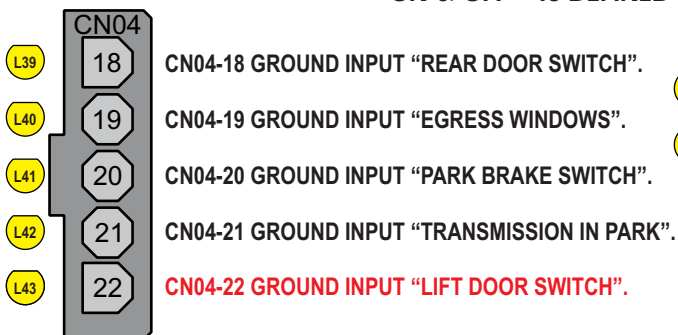

LOCATION: BOTTOM LEFT SIDE OF RCT-01760-O

1. NOTE: “ADA STOP REQUEST”, at input CN08-39, latches audible buzzer, cancels only with input at “LIFT DOOR SWITCH”, CN04-22.
2. NOTE: “PASSENGER STOP REQUEST”, at input CN08-40, latches audible buzzer, cancels only with operation of dash mounted, “Door Open and Close Switch”.

R.C. TRONICS, INCORPORATED

2573 EAST KERCHER ROAD
GOSHEN, INDIANA 46526
<https://www.rctronics.com>

PHONE: 1-574-642-3857
FAX: 1-574-642-3858
TOLL FREE: 1-866-457-7790

RCT-01760-O DIP SWITCH G IGNITION LOCK WITH UNLOCKED, REAR DOOR.

Monday, May 6, 2024

D/SW-G: Switch 1 "ON", "LOCKS IGNITION ON" and "SYSTEM LOCK, RED LED L95" when 12vdc is present at CN10-47, "REAR DOOR UNLOCKED".

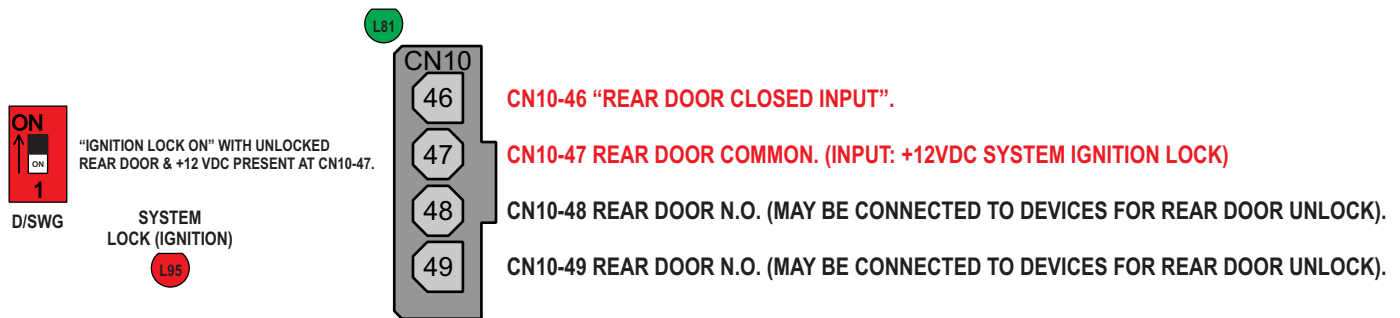

LOCATION: RIGHT TOP SIDE OF RCT-01760-M

1. NOTE: Green Led L81 "ON" indicates, "REAR DOOR CLOSED".

NOTE:

**PROTRUDING DIP-SWITCH TABS ARE ADJUSTMENT TABS SHOWN IN BLACK.
"ON & OFF" IS DEFINED IN BLACK ON WHITE BACKGROUND.**

R.C. TRONICS, INCORPORATED

2573 EAST KERCHER ROAD
GOSHEN, INDIANA 46526
<https://www.rctronics.com>

PHONE: 1-574-642-3857
FAX: 1-574-642-3858
TOLL FREE: 1-866-457-7790

RCT-01760-O Dip Switch H Buzzer with Egress Window, Rear Door, Lift Door, Stop Request. Sunday, May 5, 2024

EGRESS WINDOW, REAR DOOR, LIFT DOOR, ADA STOP REQUEST SETTINGS

- D/SW-H Switch 1 (OFF) “Egress Window”, no monitoring with audible alarm at CN04-19.
- D/SW-H Switch 1 (ON) “Egress Window”, monitoring with audible alarm at CN-04-19.
- D/SW-H Switch 2 (OFF) “Rear Door”, no monitoring with audible alarm at CN04-18.
- D/SW-H Switch 2 (ON) “Rear Door”, monitoring with audible alarm at CN04-18.
- D/SW-H Switch 3 (OFF) “Lift Door”, no monitoring with audible alarm at CN04-22.
- D/SW-H Switch 3 (ON) “Lift Door”, monitoring with audible alarm at CN04-22.
- D/SW-H Switch 4 (OFF), “ADA & Stop Request”, inhibits audible alarm at CN08-39 and CN08-40.
- D/SW-H Switch 4 (ON), “ADA & Stop Request”, enables audible alarm at CN08-39 or CN08-40.

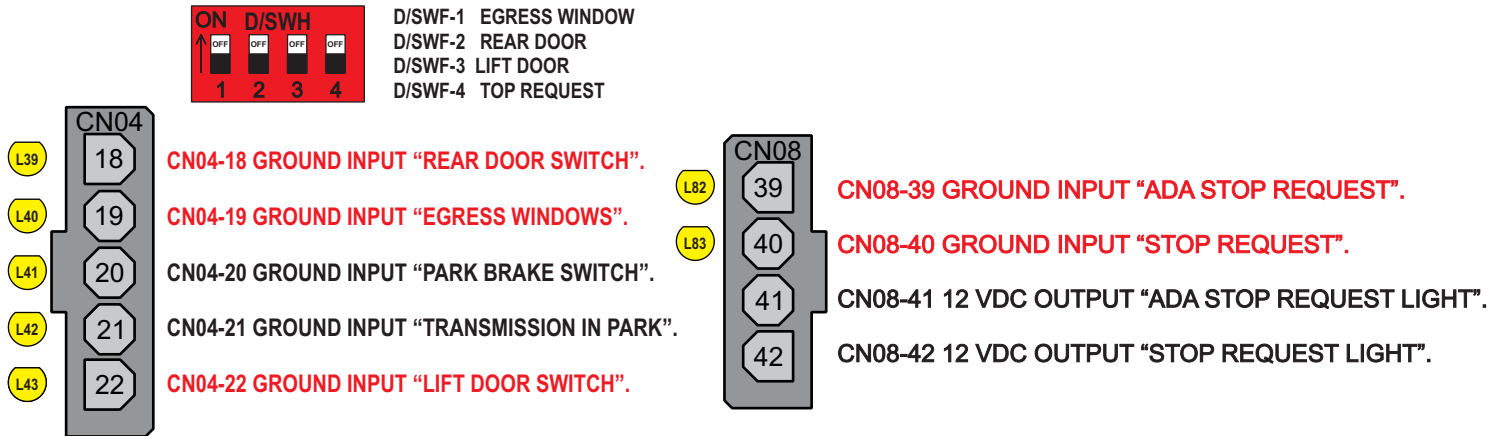

LOCATION: BOTTOM LEFT SIDE OF RCT-01760-O

1. NOTE: Switch 4 “OFF”, inhibits audible alarms from “ADA CN08-39” and “Stop Request CN08-40”.
2. NOTE: Switch 4 “ON” enables audible alarms from “ADA CN08-39” or “Stop Request CN08-40”.

NOTE:
PROTRUDING DIP-SWITCH TABS ARE ADJUSTMENT TABS SHOWN IN BLACK.
“ON & OFF” IS DEFINED IN BLACK ON WHITE BACKGROUND.

R.C. TRONICS, INCORPORATED

WWW.RCTRONICS.COM

2573 EAST KERCHER ROAD
PHONE: 1-574-642-3857
TOLL FREE: 1-866-457-7790

GOSHEN, INDIANA 46526
FAX: 1-574-642-3858
dchiddister@rcronics.com

POWER CENTER RCT-01760 DATA CABLE

J1 and J2, Cable Interface between Power Center PCB and Dash Switch PCB

J1-01 -- Ignition (+12 VDC) ---(To J3-8 and J3-7)
J1-02 -- Buzzer Output (NEGATIVE) (sink)
J1-03 -- Entry Door Light (NEGATIVE) (sink) ---(To J3-6)
J1-04 -- Stop Request (NEGATIVE) (sink) ---(To J3-5)
J1-05 -- Rear Door Light (NEGATIVE) (sink) ---(To J3-4)
J1-06 -- Egress Windows (NEGATIVE) (sink) ---(To J3-3)
J1-07 -- ADA Stop Request (NEGATIVE) (sink)--- (To J3-2)
J1-08 -- Lift Door Light (NEGATIVE) (sink) ---(To J3-1)
J1-09 -- Aux. 5/A Switch (NEGATIVE) (sink) ---(To J4-6)
J1-10 -- Aux 4/B Switch (NEGATIVE) (sink) (---To J4-7)
J1-11 -- Aux. 4/A Switch (NEGATIVE) (sink) ---(To J4-8)
J1-12 -- Aux 3/B Switch (NEGATIVE) (sink) (---To J4-9)
J1-13 -- Aux. 3/A Switch (NEGATIVE) (sink)
J1-14 -- Aux. 2/A Switch (NEGATIVE) (sink)
J1-15 -- Aux. 2/B Switch (NEGATIVE) (sink)
J1-16 -- Aux. 1 Switch (NEGATIVE) (sink)
J1-17 -- Lift Solenoid Switch (NEGATIVE) (sink)
J1-18 -- Dome Light Switch (NEGATIVE) (sink)
J1-19 -- Entry Door Close Switch (NEGATIVE) (sink)
J1-20 -- Entry Door Open Switch (NEGATIVE) (sink)

J2-01 -- Aux. 5/B Switch (NEGATIVE) (sink) ---(To J4-5)
J2-02 -- Aux. 6/A Switch (NEGATIVE) (sink) ---(To J4-4)
J2-03 -- Aux 6/B Switch (NEGATIVE) (sink) ---(To J4-3)
J2-04 -- Aux 7/A Switch (NEGATIVE) (sink) ---(To J4-2)
J2-05 -- Aux. 7/B Switch (NEGATIVE) (sink) ---(-o J4-1)
J2-06 -- Master Switch (NEGATIVE) (sink)
J2-07 -- Flasher Switch (NEGATIVE) (sink)
J2-08 -- Battery Negative (-)
J2-09 -- Clearance Light Power (+12 VDC)
J2-10 -- OPEN

J3 Connector, Indicating Lights

J3-1 Shift Lock (NEGATIVE) (sink) @ 1 ampere
J3-2 Transmission Park (NEGATIVE) (sink) @ 1 ampere
J3-3 Lift Enabled (NEGATIVE) (sink) @ 1 ampere
J3-4 Park Brake (NEGATIVE) (sink) @ 1 ampere

J3-5 Lift Door Open (**NEGATIVE**) (**sink**) @ 1 ampere

J3-6 Lift Switch On (**NEGATIVE**) (**sink**) @ 1 ampere

J3-7 Ignition (**+12 VDC**), switched)

J3-8 Ignition (**+12 VDC**), switched)

R. C. Tronics Incorporated

2573 East Kercher Road
Goshen, Indiana 46528
Toll Free 1-866-457-7790

DAT-01348-XXXXX
08 Conductor Data Cable

Phone 1-574-642-3857
Fax 1-574-642-3858
<http://www.rctronics.com>

Viewed with Tyco Connector Plug-In Face Down.



Carol C-2465, 22 AWG, Stranded 7/30/8, unshielded eight conductor cable.
Cut each jacket end 4 inches long, remove jacket on each end. Add heatshrink with DAT part number.

Requires two (2) Tyco/Amp. 643814-8 connector & Tyco/Amp. 643075-8 end cap.
Place connector into insertion equipment, start with #8 and complete with #1

CHECK CABLE WITH CABLE CHECKER

#1 BLACK, #2 RED, #3 GREEN, #4 BROWN,

#5 BLUE, #6, ORANGE, #7 YELLOW, #8 WHITE

D
A
T

1st three Letters = Data Cable

0
0
0
0
0

2nd five numbers = Print Number

0
0

3rd two numbers = Configuration

0
0

4th two numbers = Length In Feet

0

5th last digit = Length In Inches

R. C. Tronics Incorporated

2573 East Kercher Road
Goshen, Indiana 46528
Toll Free 1-866-457-7790

DAT-01349-06XXX
10 Conductor Data Cable

Phone 1-574-642-3857
Fax 1-574-642-3858
<http://www.rctronics.com>

Viewed with Tyco Connector Plug-In Face Down.



DAT-01349-06006 (6 Inch)

Carol C-9540, 24 AWG, Stranded 7/32/10,

Foil 24 AWG Gnd shielded ten conductor cable.

Cut each jacket end 4 inches long, remove jacket on each end.

Add heatshrink with DAT part number.

Requires one (1) Tyco/Amp. 1-643814-0 connector & Tyco/Amp. 1-643075-0 end cap.

Place connector into insertion equipment, start with #10 and complete with #1

#1 GREY, #2 VIOLET, #3 BLACK, #4 RED, #5 GREEN

#6 BROWN, #7 BLUE, #8 ORANGE, #9 YELLOW, #10 WHITE

D
A
T

1st three Letters = Data Cable

0
0
0
0
0

2nd five numbers = Print Number

0
0

3rd two numbers = Configuration

0
0

4th two numbers = Length In Feet

0

5th last digit = Length In Inches

R. C. Tronics, Incorporated

2573 East Kercher Road
Goshen, Indiana 46528
Toll Free: 1-886-457-7790

Phone: 1-574-642-3857
Facsimile: 1-574-642-3858
<https://www.rctronics.com>

RCT-01760-O: Trouble Shooting **“LIFT ENABLING SYSTEM”**

1. Positive +12 vdc input at, “IGNITION”, CN06-31
2. Negative signal at, “PARK BRAKE SWITCH”, CN04-20, (Amber Led, on).
3. Negative signal at, “TRANSMISSION PARK”, CN04-21, (Amber Led, on).
4. Negative signal at, “LIFT DOOR SWITCH”, CN04-22, (Amber Led, on).
5. Place, “LIFT SWITCH”, “ON”, located on dash switch assembly, J1-17 sink.
6. Positive output to, “LIFT SOLENOID”, CN03-12
7. Open fuse L194 Red Led L2, should be “OFF”.
8. Relay energized F25, Amber Led L79, should be “ON”.
9. Relay output to, “LIFT SOLENOID”, CN03-12, L93 Green Led should be “ON”.

NOTE: All four inputs must be present, 1 through 5 in which to produce an output at “LIFT SOLENOID”, CN03-12. Monitoring Led’s show status of fuse, relay coil and relay output.

R. C. Tronics, Incorporated

2573 East Kercher Road
Goshen, Indiana 46528
Toll Free: 1-886-457-7790

Phone: 1-574-642-3857
Facsimile: 1-574-642-3858
<https://www.rctronics.com>

RCT-01760-H, ADA LIFT SYSTEM, TROUBLE-SHOOTING.

Monday, November 20, 2023

1. CN04-20, ENSURE AMBER INDICATOR ILLUMINATED (L41), **“PARK BRAKE SWITCH”**.
2. CN04-21, ENSURE AMBER INDICATOR ILLUMINATED (L42), **“TRANSMISSION PARK”**.
3. CN04-22, ENSURE AMBER INDICATOR ILLUMINATED (L43), **“LIFT DOOR OPEN”**.
4. OPERATE, **“LIFT SWITCH, “ON”**. (INPUT, J1-17 & D19, LEFT SIDE).
- 5. NOTE: GREEN LED (L93) & AMBER LED (L79) INDICATORS ILLUMINATED.**

NOTE 1: With all five led illuminated the control will present +12 vdc at, CN03-12, **“LIFT SOLENOID OUTPUT”**, (GREEN LED, (L93).

NOTE 2: **“LIFT DOOR SWITCH”**, circuit path is from switch, dash PCB to, J1-17 and then to D19, left side. This is a sink, (ground or vdc common). Check to verify if step number 5 is not present.

NOTE 3: With the above steps complete, inputs verified, one of two conditions exist.

- Power Supply is Defective, (VR1)
- Integrated Circuit is Defective, (U1).

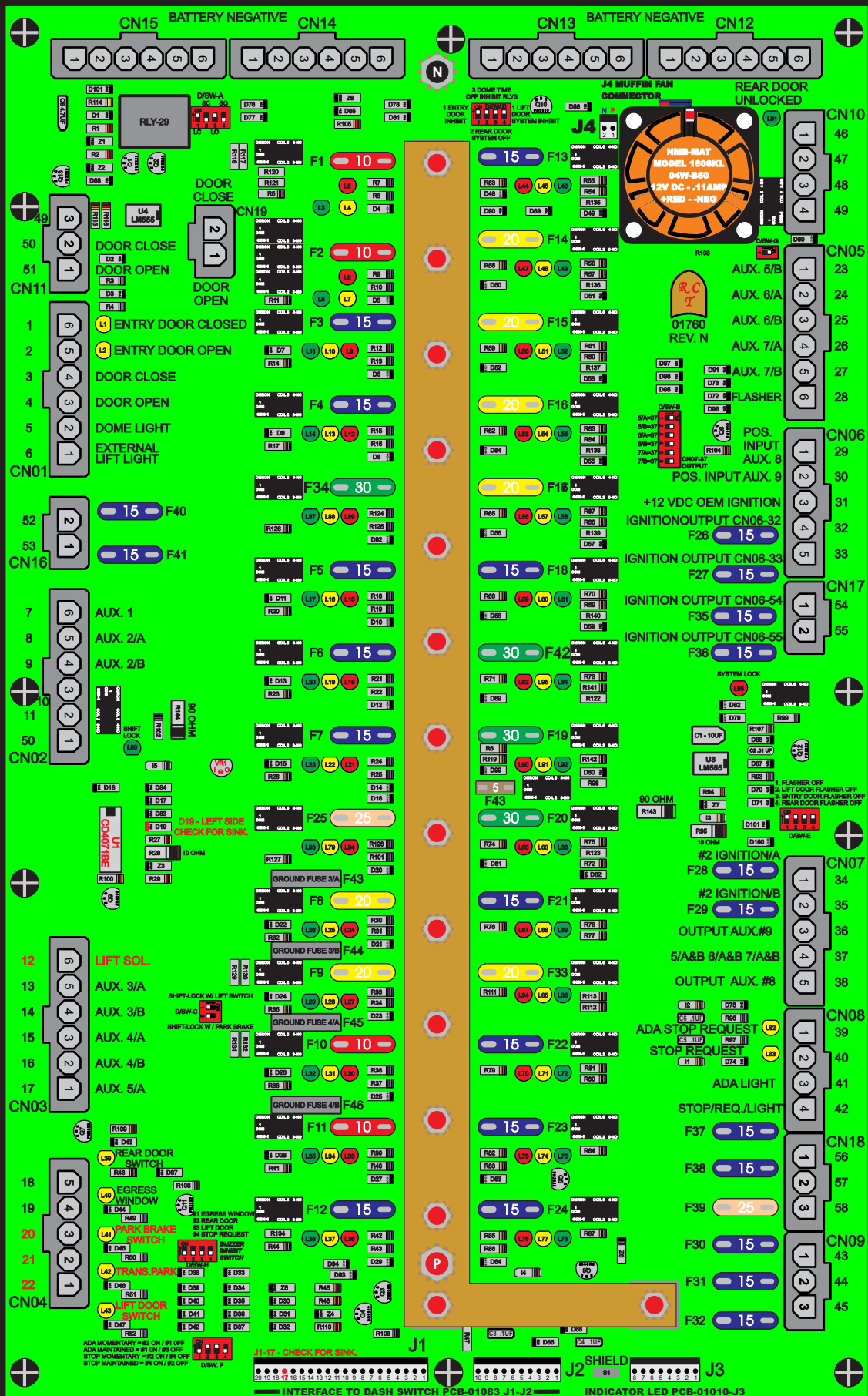

R. C. Tronics, Incorporated

Specializing In Electronic Controls

**2573 East Kercher Road
Goshen, Indiana 46528
<https://www.rctronics.com>**

**Phone: 1-574-642-3857
Fax: 1-574-642-3858
Toll Free: 1-866-457-7790**

RCT-01760-O TRANSIT BUS BOOKLET



Custom Design of Electronic Controls

Printed Circuit Board Layout

Complete Manufacturing Facility

RCT Can Solve Your Electrical /Electronic Control Requirements